

# **J-Lite JLA-10.500 Fixed Angle Rotor Assembly**

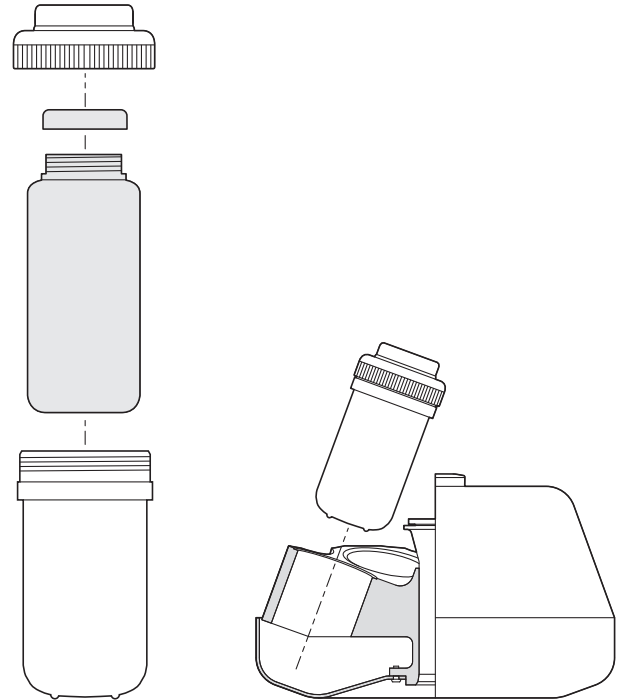
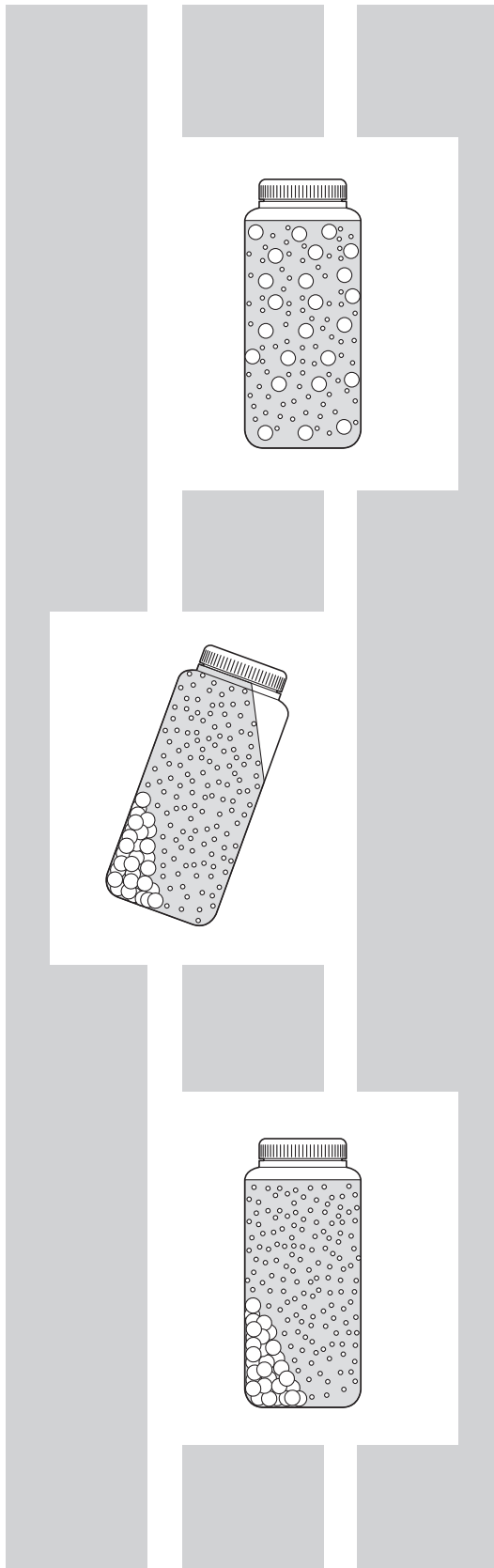

Please read and follow all of the instructions in this manual, and pay special attention to the safety information on pages 2 and 3.

**Used In Beckman Coulter J2 and  
Avanti J Series Centrifuges**

## **Trademarks**

Beckman Coulter, the stylized logo, and Avanti are trademarks of Beckman Coulter, Inc. and are registered in the USPTO.

All other trademarks, service marks, products, or services are trademarks of their respective holders.



## SAFETY NOTICE

This safety notice summarizes information basic to the safe use of the rotor described in this manual. The international symbol displayed above is a reminder to the user that all safety instructions should be read and understood before operation or maintenance of this equipment is attempted. When you see the symbol on other pages throughout this publication, pay special attention to the specific safety information presented. Observance of safety precautions will also help to avoid actions that could damage or adversely affect the performance of the rotor.



Handle body fluids with care because they can transmit disease. No known test offers complete assurance that they are free of micro-organisms. Some of the most virulent—Hepatitis (B and C) and, HIV (I–V) viruses, atypical mycobacteria, and certain systemic fungi—further emphasize the need for aerosol protection. Handle other infectious samples according to good laboratory procedures and methods to prevent spread of disease. Because spills may generate aerosols, observe proper safety precautions for aerosol containment. Do not run toxic, pathogenic, or radioactive materials in this rotor without taking appropriate safety precautions. Biosafe containment should be used when Risk Group II materials (as identified in the World Health Organization *Laboratory Biosafety Manual*) are handled; materials of a higher group require more than one level of protection.



The rotor and accessories are not designed for use with materials capable of developing flammable or explosive vapors. Do not centrifuge such materials in nor handle or store them near the centrifuge.



This rotor was developed, manufactured, and tested for safety and reliability as part of a Beckman Coulter centrifuge/rotor system. Its safety or reliability cannot be assured if used in a centrifuge not of Beckman Coulter's manufacture or in a Beckman Coulter centrifuge that has been modified without Beckman Coulter's approval.



If disassembly reveals evidence of leakage, you should assume that some fluid escaped the rotor. Apply all appropriate safety and decontamination procedures to the centrifuge and accessories as required.



Never exceed the maximum rated speed of the rotor and labware in use. Refer to the section on RUN SPEEDS.



Do not use sharp tools on the rotor that could cause scratches in the rotor surface. Corrosion begins in scratches and may open fissures in the rotor with continued use.

**Additional information for the safe use of the J-Lite JLA-10.500 rotor assembly.  
Please read before use.**

- Use all rotor components during each run, as shown below. Six cannisters must be run at all times, whether loaded or empty.

- Place filled bottles inside cannisters. NEVER place sample directly into a cannister.

- Securely attach a cannister closure to each cannister.

- Place cannisters in the cavities in the rotor body. NEVER place bottles directly into the rotor cavities.

- Place the rotor lid on top of the rotor and fasten the round tie-down knob securely.

- Place filled, sealed cannisters in at least two opposing cavities; place empty, sealed cannisters in all other cavities. Make sure that filled cannisters are loaded symmetrically into the rotor and that opposing containers are filled to the same level with liquid of the same density.

- The maximum speed of 500-mL capped polypropylene bottles (361961) is 8 000 rpm. (See page 14 for complete bottle and tube information.)

- Although rotor components and accessories made by other manufacturers may fit in the JLA-10.500 rotor, their safety in this rotor cannot be ascertained by Beckman Coulter. Use of other manufacturers' components in the JLA-10.500 rotor may void the rotor warranty and should be prohibited by your laboratory safety officer. Only the components listed in this publication should be used in this rotor.

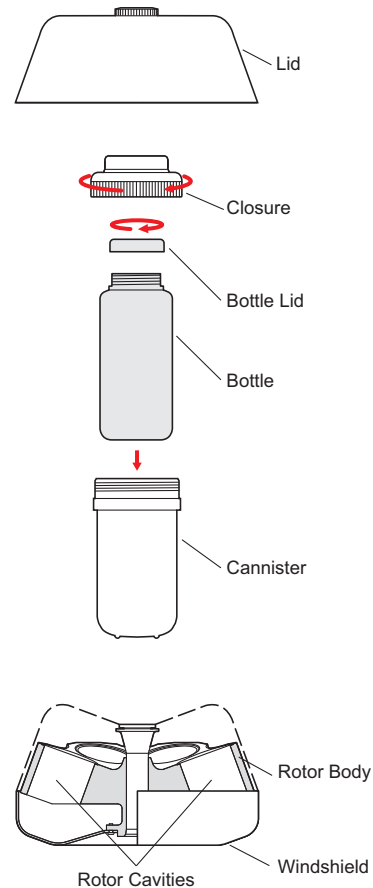

## J-Lite JLA-10.500 Fixed Angle Rotor Assembly

### SPECIFICATIONS

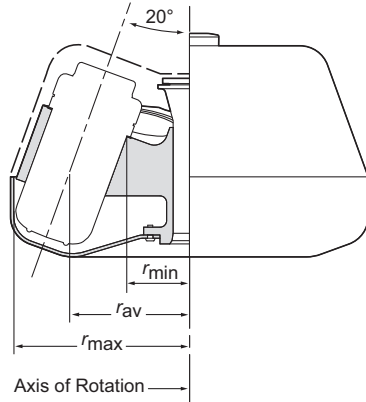

U.S. Patent Nos. 5855289, 5899349

Maximum speed	10 000 rpm
Critical speed range*	600 to 800 rpm
Maximum solution density	1.2 g/mL
Relative Centrifugal Field <sup>†</sup> at maximum speed	
at $r_{max}$ (166 mm)	18 600 × $g$
at $r_{av}$ (110 mm)	12 300 × $g$
at $r_{min}$ (54 mm)	6 050 × $g$
$k$ factor at maximum speed (full 500-mL bottle)	2 850
Conditions requiring speed reduction	see SPEED LIMITS
Number of removable cannisters	6
Available bottles and tubes	see Tables 3 and 4
Nominal dimensions of largest bottle	69 × 160 mm
Nominal bottle capacity	500 mL
Nominal rotor capacity	3 liters
Weight of fully loaded rotor (with lid)	16.2 kg (35.7 lb)
Minimum installation weight (rotor body and windshield)	8.9 kg (19.7 lb)
Weight of single empty cannister	240 g (0.53 lb)
Maximum sample load for each cannister at rated speed (including labware and sample; not including closure, if applicable)	665 g (1.47 lb)
Approximate acceleration time to maximum speed (rotor fully loaded) in an Avanti J-25 centrifuge	2 1/2 min
Approximate deceleration time from maximum speed (rotor fully loaded, max. brake) in an Avanti J-25 centrifuge	2 min
Maximum allowable imbalance of opposing loads	10 g
Rotor body material	aluminum
Cannister material	carbon fiber epoxy composite
Rotor entry code for Avanti J-E and microprocessor-controlled J2 series centrifuges	10.5

\* The critical speed range is the range of speeds over which the rotor shifts so as to rotate about its center of mass. Passing through the critical speed range is characterized by some vibration.

<sup>†</sup> Relative Centrifugal Field (RCF) is the ratio of the centrifugal acceleration at a specified radius and speed ( $r\omega^2$ ) to the standard acceleration of gravity ( $g$ ) according to the following formula:

$$RCF = \frac{r\omega^2}{g}$$

where  $r$  is the radius in millimeters,  $\omega$  is the angular velocity in radians per second ( $2\pi \text{ RPM} / 60$ ), and  $g$  is the standard acceleration of gravity ( $9807 \text{ mm/s}^2$ ). After substitution:

$$RCF = 1.12 r \left( \frac{\text{RPM}}{1000} \right)^2$$

## DESCRIPTION

*This rotor has been manufactured in a registered ISO 9001 or 13485 facility for use in the specified Beckman Coulter centrifuges.*

The J-Lite JLA-10.500 fixed angle rotor assembly, rated for 10 000 rpm, has a tube angle of 20 degrees from the axis of rotation. Used in Beckman Coulter Avanti J and J2 series centrifuges (not for use in J-21 series), the rotor develops centrifugal forces that can efficiently pellet cells from large volumes of culture media, cell particles from tissue homogenates, or subcellular organelles. Short column methods (such as partially filled tubes) may also be used to purify large quantities of low-sedimentation particles (such as viruses) in a cushion gradient.

The JLA-10.500 rotor assembly consists of a rotor body with attached windshield, a rotor lid and lid knob, and six removable carbon fiber cannisters (see Figure 1). Each cannister can hold one 500-mL bottle or a variety of tubes and bottles with adapters. The cannisters have closures (lids) that provide substantial secondary containment of sample in the event of tube or bottle breakage. The cannisters are fully interchangeable, allowing the use of multiple sets of cannisters with a single rotor body.

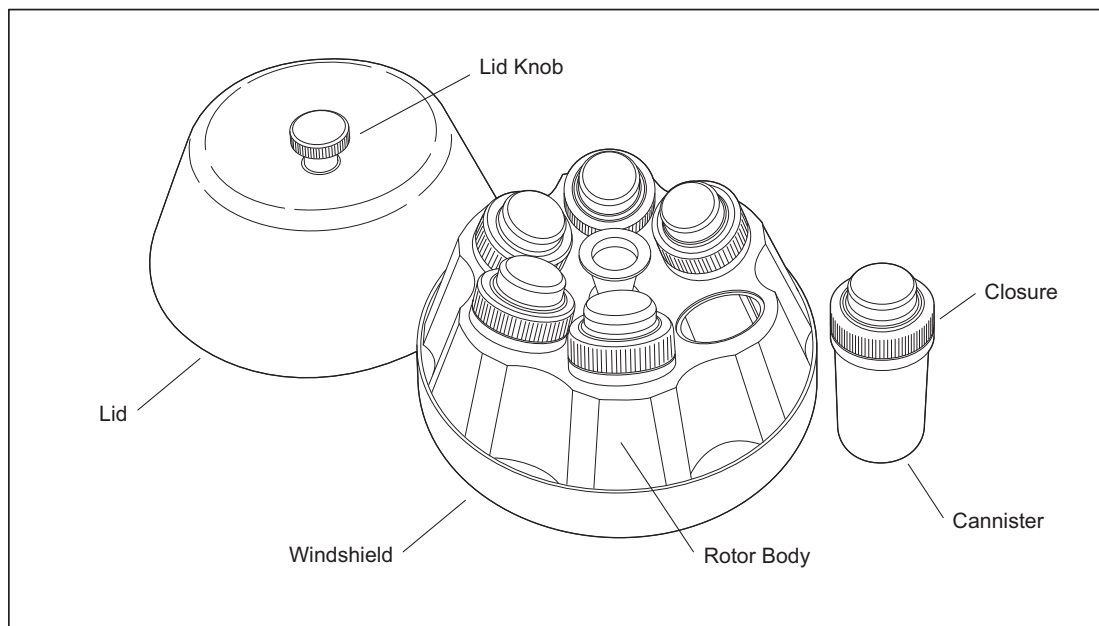

*Figure 1. The JLA-10.500 Fixed Angle Rotor*

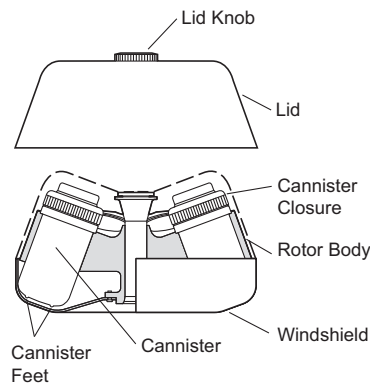

The rotor body, windshield, and lid are made of anodized aluminum; the cannisters are made of lightweight carbon fiber epoxy composite. This combination of materials makes the overall rotor weight approximately 30 percent lighter than a comparably sized all-aluminum rotor. Removing the cannisters before loading the rotor into the centrifuge or before removing the rotor from the centrifuge lowers the rotor's minimum load/unload weight by almost 50 percent, as compared to a traditional fixed-angle aluminum rotor.

Two pins in the rotor drive hole seat alongside the centrifuge drive hub teeth, preventing the rotor from slipping during centrifugation. The lid knob secures the rotor to the centrifuge drive hub. A lubricated ethylene propylene rubber O-ring inside the cannister closure helps to create a secondary liquid seal during centrifugation. Six raised resin feet on the bottom of each cannister enable cannisters to stand upright on a flat surface.

Starting in 2002, JLA-10.500 rotors are manufactured with magnets embedded in the rotor base for rotor identification in the Avanti J-E centrifuge. Older JLA-10.500 rotors without magnets can be used in the Avanti J-E, but the rotor speed will be limited to 6300 rpm. (Other Avanti J series and J2 series centrifuges use alternate methods of rotor identification that enable the rotor to run up to 10 000 rpm.)

The rotor has been tested<sup>1</sup> to demonstrate containment of microbiological aerosols under normal conditions of the associated Beckman Coulter centrifuge when used and maintained as instructed.

For warranty information, see the WARRANTY at the back of this manual.

## PREPARATION AND USE

*Specific information about the JLA-10.500 rotor assembly is given here. Use the J Series Rotors and Tubes manual (JR-IM) for complete rotor and accessory information.*

<sup>1</sup> Validation of microbiological containment was done at an independent third-party testing facility (CAMR, Porton Down, UK, or USAMRIID, Ft. Detrick, MD, U.S.A.). Improper use or maintenance may affect seal integrity and thus containment.

## PRERUN SAFETY CHECKS

---

*Read the safety information on pages 2 and 3 of this manual before using the rotor.*

1. Make sure that the rotor and lid are clean and show no signs of corrosion or cracking.
2. Inspect the cannisters for damage (see Information About Carbon Fiber Epoxy Composite Cannisters, later in this manual).
3. Check the chemical compatibilities of all materials used (refer to Appendix A in *Rotors and Tubes*.)
4. Verify that the tubes being used are listed in Table 3.

## ROTOR PREPARATION

---



*For runs at other than room temperature, refrigerate or warm the rotor beforehand for fast temperature equilibration. If you regularly perform low-temperature runs, store the cannisters in a refrigerator between runs.*

1. Be sure that metal threads in the rotor drive hole are clean and lightly but evenly lubricated with Spinkote lubricant (306812). Also ensure that cannister O-rings are in good condition and that O-rings and cannister threads are lightly but evenly coated with silicone vacuum grease (335148).
2. Place sample in bottles, secure bottle caps if applicable, and place each bottle in a cannister. (Or, load tubes, place tubes in the appropriate adapters, and place each adapter in a cannister). Opposing bottles or tubes must be filled to the same level with liquid of the same density. Load cannisters symmetrically into the rotor (see Figure 2); opposing loads must balance to within 10 g.

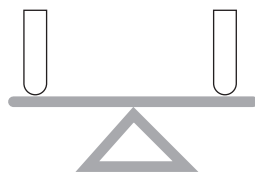

If you are running fewer than six loaded cannisters, place loaded cannisters opposite each other on the rotor body and place empty cannisters in the other rotor cavities. NEVER place sample directly into the cannisters, and NEVER place filled bottles or tubes directly into the rotor cavities.

3. Before each run, make sure the rotor is seated on the centrifuge drive hub, that all cannister closures are tight, and that the lid knob is tight.



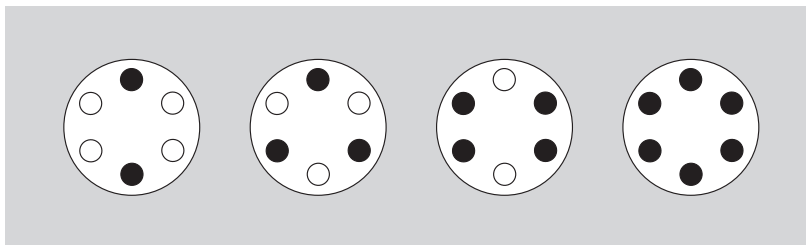

*Figure 2. Arranging Loads in the Rotor.  
Two, three, four, or six loads can be centrifuged per run,  
if they are placed in cannisters and arranged in the rotor as shown.  
Six cannisters must be run, whether loaded or empty.*

## **BEFORE USING THE JLA-10.500 IN A MICROPROCESSOR-CONTROLLED J2 SERIES CENTRIFUGE**

---

If you have a microprocessor-controlled J2 series centrifuge (model J2-MI or J2-MC), you will need to enter the JLA-10.500 rotor identification code (10.5) and maximum speed (10 000 rpm) into the instrument memory *before the first use of the JLA-10.500 rotor in that instrument*. Use the following instructions.

### **NOTE**

These steps are not required with Avanti J series centrifuges.

---

1. On the centrifuge panel, press and hold the [ROTOR] key. While holding [ROTOR], press [PROG SAVE]. Release both keys. The rotor display area will show 1 -- . -- . This indicates that you are ready to program the first entry, which is the rotor identification code **10.5**. Enter **10.5**, again press and hold the [ROTOR] key, press [PROG SAVE], and then release both keys.
2. The rotor display should now show 2 -- . -- . You are now ready to program the second entry, which is the JLA-10.500 rotor's maximum speed of 10 000 rpm. Enter 10.0; again press and hold [ROTOR], press [PROG SAVE], and release both keys.
3. The rotor display should now show 3 -- . -- . The third entry programs the temperature compensation for the rotor. It is not possible, however, to enter a compensation value at this step; you must enter 0. Entering temperature compensation is discussed below (see TEMPERATURE) since it is programmed differently and can be entered only after these three steps have been completed.

4. To complete the entry, press and hold [ROTOR], then press [ENTER/RECALL], and release both keys. The display should now return to normal.

If you make an error, or if you wish to review the entered information, press both [ROTOR] and [PROG SAVE] repeatedly to cycle through levels 1, 2, and 3. The program can only be logged into memory from level 3, and only when all three entries are complete.

Once this procedure is complete, the memory will retain the information and it will not have to be entered again. When you are ready to run the JLA-10.500 rotor, enter code **10.5** as described in the centrifuge instruction manual.

## LOADING THE CANNISTERS

---

### Working with Physiological Fluids

---



#### **WARNING**

---

**Handle body fluids with care because they can transmit disease. No known test offers complete assurance that they are free of micro-organisms. Some of the most virulent—Hepatitis (B and C) viruses, HIV (I–V), atypical mycobacteria, and certain systemic fungi—further emphasize the need for aerosol protection.**

**Take appropriate safety precautions when handling toxic, pathogenic, or other hazardous materials.**

---

When working with potentially hazardous materials, always fill and open containers in an appropriate hood or biological safety cabinet. In addition, it is strongly recommended that all containers carrying physiological fluids be capped to prevent leakage.

## Symmetric and Balanced Loading

---

For optimal performance and stability, the JLA-10.500 rotor assembly must be loaded symmetrically. Load opposing cannisters with the same type of labware containing the same amounts of fluid of equal density.

- Six cannisters must be run at all times, whether loaded or empty.
- The weight of cannisters run in opposite positions in the rotor, including contents, must balance to within 10 grams.
- Do not exceed the rated maximum sample load for any single cannister (665 grams, including labware and sample; not including closure).

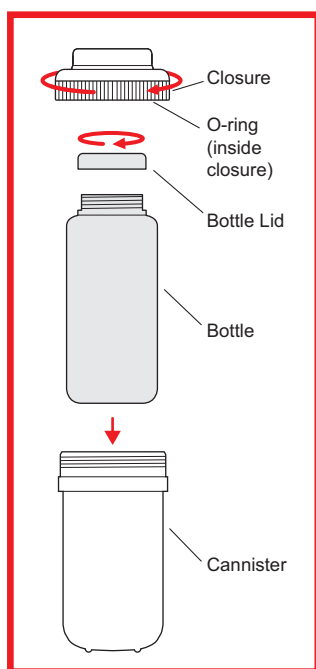

## Loading Steps

---

1. Place loaded bottles, or tubes in adapters (see Tables 3 and 4), into the cannisters. Do not use adapters in which glass tubes have broken, as pieces of glass may become embedded in the adapter and may damage subsequently used tubes.
2. Place the closure on the cannister and hand-tighten securely. *Do not use tools to tighten the closure. Over-tightening it may damage the cannister and closure threads.*
3. Place the cannisters in the rotor body (either *before or after* installing the rotor in the centrifuge). Make sure that six cannisters are installed and that opposing cannisters plus labware and sample weigh within 10 grams of each other.

## INSTALLING THE ROTOR

---

Lubricate J2 series centrifuge drive hubs with a thin, even coat of Spinkote (306812) to prevent the rotor from sticking. Avanti J series centrifuge hubs have Delrin<sup>2</sup> rings to prevent rotor sticking, and do not require lubrication.

1. Holding the scalloped edges of the rotor body with both hands, or the silver cone in the center of the rotor with one hand, carefully lower the rotor onto the centrifuge drive hub. If cannisters are not installed, you can also place your hands in the empty cannister openings—use the method you find most convenient. *Do not drop the rotor onto the hub or the hub could be damaged.* Slowly turn the rotor to make sure that it is properly seated on the centrifuge drive hub.
2. Make sure that six cannisters are installed in the rotor cavities.
3. Place the lid on the rotor and tighten the lid tie-down knob to secure the rotor to the centrifuge drive hub.



### **WARNING**

---

**Securely tighten the tie-down knob to attach the rotor body to the centrifuge drive hub. If the rotor is left in the centrifuge between runs, make sure the rotor is seated on the drive hub and the tie-down knob is tight before each run.**

---

## TEMPERATURE

---

To ensure that the JLA-10.500 rotor assembly reaches the required temperature during the run, follow the instructions below for the model of centrifuge being used.

---

<sup>2</sup> Delrin is a registered trademark of E. I. Du Pont de Nemours & Company.

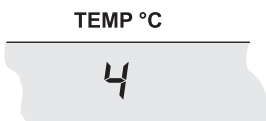

## Avanti J Series Centrifuges

Enter the run temperature according to the instructions in your centrifuge instruction manual. No additional input is required.

## J2 Series Centrifuges

Enter the required run temperature *and* the appropriate temperature compensation units (see Tables 1 and 2) on the centrifuge control panel as follows.

*Analog J2 Series Centrifuges (Models J2-HS and J2-HC):*

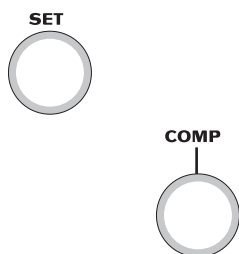

1. Turn the SET knob on the centrifuge control panel to the required sample temperature.
2. Find the compensation value in Table 1 or Table 2 that corresponds with the required temperature and run speed. Set the COMP dial to that setting. Interpolate if intermediate values are required.

*Table 1. Temperature Compensation Settings for the Models J2-HS, J2-MI, and J2-MC Centrifuges. Interpolate if intermediate values are required.*

Rotor Speed (rpm)	Required Sample Temperature (°C)						
	-20	-10	2	5	10	20	40
10 000	N*	-5 <sup>†</sup>	-2	-1	0	+2	+1
8 000	-1 <sup>†</sup>	-1 <sup>†</sup>	0	+2	+2	+3	+1
5 000	0 <sup>†</sup>	-1	+2	+1	+4	+3	+1

\* An "N" indicates that the rotor cannot achieve the required temperature at this speed.

<sup>†</sup> Above 30°C ambient temperature, this temperature may not be achieved at this speed.

Table 2. Temperature Compensation Settings for the Model J2-HC Centrifuge.  
Interpolate if intermediate values are required.

Rotor Speed (rpm)	Required Sample Temperature (°C)						
	-20	-10	2	5	10	20	40
10 000	N*	-6 <sup>†</sup>	-3	-3	-3	-1	0
8 000	-3 <sup>†</sup>	-3	-3	-2	-2	-1	0
5 000	-3 <sup>†</sup>	-2	-2	-1	0	0	+2

\* An “N” indicates that the rotor cannot achieve the required temperature at this speed.

<sup>†</sup> Above 30°C ambient temperature, this temperature may not be achieved at this speed.

*Microprocessor-Controlled J2 Series Centrifuges (Models J2-MI and J2-MC):*

TEMPERATURE °C

COMP

1. Enter the required sample temperature by pressing the [TEMP] key on the centrifuge control panel and pressing the appropriate keys on the keypad.
2. Find the compensation value in Table 1 that corresponds with the required temperature and run speed.
3. Press [COMP ADJ]. The word “COMP” flashes below the TEMPERATURE display and the display flashes.
4. Press the appropriate keyboard digits to enter the compensation value. Press the [±.] key to enter a minus sign; pressing it again will remove the minus sign.
5. Check the temperature display. If the entry is incorrect, press [ce] and reenter the digits.
6. When the entry is correct, press [ENTER/RECALL].

**NOTE**

To clear a COMP ADJ entry, press [COMP ADJ], [0], and [ENTER/RECALL].

## REMOVAL AND SAMPLE RECOVERY

---



### CAUTION

---

*If disassembly reveals evidence of leakage, you should assume that some fluid escaped the rotor. Apply appropriate decontamination procedures to the centrifuge and accessories as required.*

---

### Removing Cannisters

---

1. Unscrew the rotor lid knob. Remove the lid and set it aside.
2. Remove the cannisters from the rotor, before or after removing the rotor from the centrifuge.
3. Unscrew the closures and remove the installed labware and sample. Sealed cannisters may be placed under a safety hood before closures are removed.

## TUBES AND BOTTLES

---

The JLA-10.500 rotor assembly uses the tubes and bottles listed in Table 3. Be sure to use only those items listed, and to observe the maximum fill volumes and speed limits shown. Refer to Appendix A in *Rotors and Tubes* for information on the chemical resistances of tube and accessory materials.

Table 3. Available Tubes and Bottles for the JLA-10.500 Fixed Angle Rotor Assembly.  
Use only the items listed here and observe fill volumes and maximum run speeds.

Tube			Max Fill Vol <sup>a</sup> (mL)	Required Accessory		Max Speed <sup>b/</sup> RCF
Dimensions and Volume	Description	Part Number		Description	Part Number	
69 × 160 mm 500 mL	polycarbonate bottle w/cap assy	361690	465	none	—	10 000 rpm 18 600 × g
69 × 160 mm 500 mL	polypropylene bottle w/cap assy	361691	445	none	—	8 000 rpm 11 900 × g
62 × 120 mm 250 mL	polypropylene wide mouth bottle w/cap assy	356011	250	adapter <sup>d</sup>	362750	10 000 rpm 17 700 × g
62 × 120 mm 250 mL	polycarbonate wide mouth bottle w/cap assy	356013	250	adapter <sup>d</sup>	362750	10 000 rpm 17 700 × g
29 × 104 mm 50 mL	polycarbonate open-top tube	363647	40	adapter <sup>c</sup>	356996	10 000 rpm 12 000 × g
29 × 104 mm 50 mL	polycarbonate tube w/snap-on cap	363664	40	adapter <sup>c</sup>	356996	10 000 rpm 12 000 × g
29 × 104 mm 50 mL	polycarbonate bottle assy w/liquid-tight cap assy	357000	42	adapter <sup>c</sup>	356996	10 000 rpm 12 000 × g
29 × 104 mm 50 mL	polypropylene bottle assy w/liquid-tight cap assy	357001	42	adapter <sup>c</sup>	356996	10 000 rpm 12 000 × g
29 × 104 mm 50 mL	polycarbonate bottle w/screw cap	357002	34	adapter <sup>c</sup>	356996	10 000 rpm 12 000 × g
29 × 104 mm 50 mL	polypropylene bottle w/screw cap	357003	34	adapter <sup>c</sup>	356996	10 000 rpm 12 000 × g
29 × 104 mm 50 mL	polypropylene thickwall tube w/snap-on cap	357005	31	adapter <sup>c</sup>	356996	10 000 rpm 12 000 × g
				natural 29-mm cap red 29-mm cap green 29-mm cap yellow 29-mm cap blue 29-mm cap	356264 <sup>e</sup> 357359 <sup>e</sup> 357360 <sup>e</sup> 357361 <sup>e</sup> 357362 <sup>e</sup>	

<sup>a</sup> Above 20°C fill polypropylene tubes at least half full.

— Continued

<sup>b</sup> Maximum speeds listed are guidelines only. These speeds have been achieved in reliability tests at Beckman Coulter, but, because of manufacturing variances, no guarantee of performance or fit is expressed or implied.

<sup>c</sup> Polypropylene; package of 1.

<sup>d</sup> Polyethylene terephthalate (PET); package of 2.

<sup>e</sup> Polypropylene; package of 25.



Table 3. Available Tubes and Bottles for the JLA-10.500 Fixed Angle Rotor Assembly (continued)

Tube			Max Fill Vol <sup>a</sup> (mL)	Required Accessory		Max Speed <sup>b/</sup> RCF
Dimensions and Volume	Description	Part Number		Description	Part Number	
29 × 104 mm 50 mL	polypropylene thickwall tube, no cap	357007	31	adapter <sup>c</sup>	356996	10 000 rpm 12 000 × g
Bio-Vials 14 × 55 mm 4 mL	polypropylene, capped	566353	4	adapter <sup>g</sup>	342098 <sup>f</sup> and 362750 <sup>d</sup>	10 000 rpm

<sup>a</sup> Above 20°C fill polypropylene tubes at least half full.

<sup>b</sup> Maximum speeds listed are guidelines only. These speeds have been achieved in reliability tests at Beckman Coulter, but, because of manufacturing variances, no guarantee of performance or fit is expressed or implied.

<sup>c</sup> Polypropylene; package of 1.

<sup>d</sup> Polyethylene terephthalate (PET); package of 2.

<sup>e</sup> Polypropylene; package of 25.

<sup>f</sup> Delrin. Delrin is a registered trademark of E. I. Du Pont de Nemours & Company.

<sup>g</sup> Two adapters (342098) can be double-stacked inside of one adapter (362750) per cannister if greater capacity is required.

Table 4. Beckman Coulter Adapters for Commercially Available Tubes

Adapter Part Number	Tube Description	Nominal Volume (mL)	Max. Fill Volume (mL) (approx.)	Maximum Speed (rpm)	Dimensions (mm)	Maximum Number per Rotor
359398 (Delrin)	round bottom, glass	30	*	*	25 × 105	6
356994 (polypropylene)	round bottom, glass	15	*	*	17 × 100	30
356994 (polypropylene)	round bottom, glass	15	*	*	17 × 120	30
356967 (Delrin)	round bottom, glass	4	*	*	12 × 75	72
356965 (polypropylene)	conical	50	*	*	29 × 115	6
356960 (polypropylene)	conical	15	*	*	17 × 120	30

\* Observe manufacturer's speed guidelines and maximum fill volumes.

Tubes and bottles may be centrifuged at most normal operating temperatures, but should be tested under simulated conditions first when working at temperatures below 4°C or above room temperature.

The safety of accessories made by other manufacturers cannot be ascertained by Beckman Coulter. If tubes made by manufacturers other than Beckman Coulter are used, reduce rotor speed to prevent breakage. The strength of glass and plastic tubes can vary between lots, and will depend on handling and usage. Scratches (even microscopic ones) significantly weaken glass tubes. We highly recommend that you pretest labware in the rotor using water samples to determine optimal operating conditions.

## RUN TIMES

---

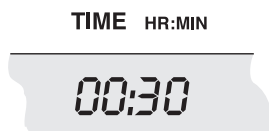

Run times for pelleting in the JLA-10.500 rotor assembly can readily be estimated if the sedimentation coefficients ( $s$ ) of the particles of interest are known. Use the following equations. The rated  $k$  factor of the rotor at maximum speed is 2850 for full 500-mL bottles and 1040 for half-full 500-mL bottles.<sup>3</sup> The run time  $t$  is in hours, and  $s$  is in Svedberg ( $S$ ) units.

$$t = \frac{k}{s} \quad (1)$$

where

$$k = k_{\text{rated}} \left( \frac{10\,000}{\text{actual run speed}} \right)^2 \quad (2)$$

For example, at 10 000 rpm in this rotor, calculations indicate that *E. coli* ( $s = 43\,200\ S$ ) will pellet in approximately 4 minutes in a full 500-mL bottle. In a half-full bottle, at 10 000 rpm, viruses ( $s \approx 700\ S$ ) will pellet in approximately 1 1/2 hours.

---

<sup>3</sup> Based on sedimentation in water at 20°C.

For containers that nominally hold less than 500 mL, the  $k$  factor is less than 2850. Calculate  $k$  factors for these containers using equation (3).

$$k_{\text{rated}} = \frac{2.53 \times 10^{11}}{\text{RPM}^2} \left( \ln \frac{a}{b} \right)^2 \quad (3)$$

where  $a$  is the actual  $r_{\text{max}}$  of the tube, measured in millimeters from the center of the rotor, and  $b$  is the actual  $r_{\text{min}}$  (radius to the liquid meniscus) of the tube. This value for  $k_{\text{rated}}$  can be substituted into equations (1) and (2) to estimate run times for these containers.

For more information on  $k$  factors, see *Use of  $k$  Factors for Estimating Run Times from Previously Established Run Conditions* (publication DS-719).

## RUN SPEEDS

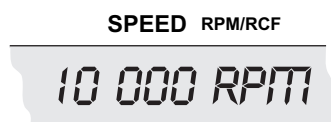

The centrifugal force at a given radius in a rotor is a function of run speed. Comparisons of forces between different rotors are made by comparing the rotor's relative centrifugal fields (RCF). When rotational speed is selected so that identical samples are subjected to the same RCF in two different rotors, the samples are subjected to the same force (see Table 5).

*Do not select rotational speeds higher than the maximums you have determined to be appropriate for your protocols (in no case above 10 000 rpm or the limits provided in Table 3). In addition, when solutions more dense than 1.2 g/mL are centrifuged in this rotor, use equation (4) to calculate the reduced maximum allowable rotor speed.*

$$\text{reduced maximum speed} = (10\,000 \text{ rpm}) \sqrt{\frac{1.2 \text{ g/mL}}{\text{density of tube contents}}} \quad (4)$$

*Note, however that the use of this formula may still produce maximum speeds higher than the limitations imposed by the use of certain tubes or adapters (see Table 3). In such cases, use the lower of the two figures.*

Table 5. Relative Centrifugal Fields for the JLA-10.500 Rotor Assembly.

Entries in this table are calculated from the formula

$$RCF = 1.12r (RPM/1000)^2$$

and then rounded to three significant digits.

Rotor Speed (rpm)	Relative Centrifugal Field (× g)		
	At $r_{max}$ (166 mm)	At $r_{av}$ (110 mm)	At $r_{min}$ (54 mm)
10 000	18 600	12 300	6 050
9 500	16 800	11 100	5 460
9 000	15 100	9 980	4 900
8 500	13 400	8 900	4 380
8 000	11 900	7 880	3 870
7 500	10 500	6 930	3 400
7 000	9 110	6 040	2 960
6 500	7 860	5 210	2 560
6 000	6 690	4 440	2 180
5 500	5 620	3 730	1 830
5 000	4 650	3 080	1 510
4 500	3 760	2 500	1 220
4 000	2 970	1 970	968
3 500	2 280	1 510	740
3 000	1 670	1 110	544
2 500	1 160	770	378
2 000	744	490	242
1 500	418	277	136
1 000	186	123	60

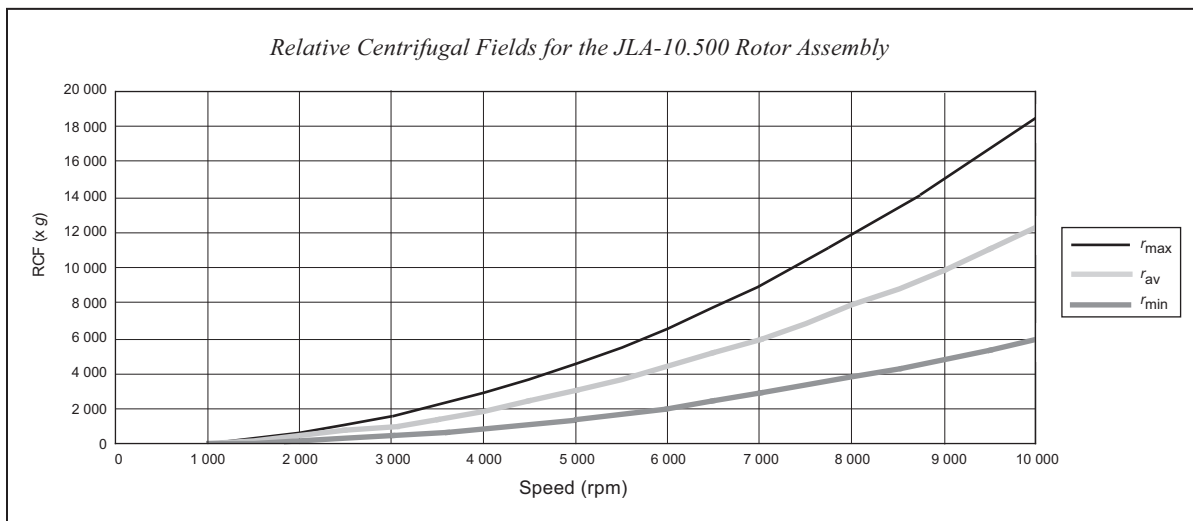

## CARE AND MAINTENANCE

### CANNISTER INSPECTION AND MAINTENANCE

---

Regularly inspect each cannister as described below.

- Before each use, inspect the cannisters for deep cracks. If any cracking or other damage is visible on the outside wall or near the aluminum-composite interface area, or if threads are visible, *do not use the cannister*. Contact your Beckman Coulter representative. New cannisters can be purchased (see the SUPPLY LIST at the back of this manual).
- Inspect the sealing surface (see Figure 3) to make sure that it is smooth and undamaged. Gouges in this surface may prevent the closure O-ring from achieving a tight seal.
- Cannister closure performance depends upon proper use and maintenance. Check the O-ring inside the closure before each use to make sure that it is in good condition, and lightly lubricate it with silicone vacuum grease before each use. Replace the O-ring if it is damaged. Closures are marked with the date of manufacture to help you keep sets of closures together.
- If a crack or blemish appears after a cannister is dropped from a height of several feet, or after it strikes a sharp edge of a bench or table, return the cannister to Beckman Coulter for inspection. See RETURNING A ROTOR on page 27.

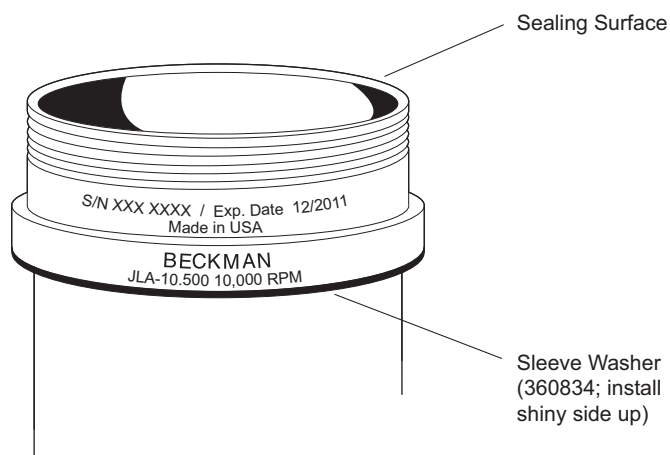

Figure 3. Cannister Sleeve Washer

- Each cannister has an expiration date, engraved on the aluminum ring around the top of the cannister (see Figure 3). *Do not use the cannister after this date* (see the Warranty for additional information). New cannisters can be used with the same rotor body. Cannister closures should be replaced when the cannisters are replaced.
- Each cannister has a yellow Ultem<sup>4</sup> sleeve washer (360834) beneath the aluminum sleeve (see Figure 3), which acts as a cushion between the cannister sleeve and the rotor body. Before each use, check to make sure that this washer is in place. If the cannister is exposed to high temperatures and/or autoclaving, the washer may loosen; if this happens, press it back in place with your finger. If it comes all the way off the cannister, replace it with the *shiny side up*.

## INFORMATION ABOUT COMPOSITE CANNISTERS

---

The carbon fiber epoxy composite material used in the JLA-10.500 cannisters is extremely strong, and ideally suited to the high stresses produced by centrifugal force. The cannisters will retain their strength throughout their 7-year life, but will exhibit certain cosmetic changes with time. The cannisters also require different inspection and handling procedures than all-metal rotor components.

After several hundred centrifuge run cycles, surface cracks may appear in the dome area of the cannister (see Figure 4) and may increase in number with continued use. Surface cracks are not uncommon in carbon fiber components, and *do not affect the structural integrity of the cannister*. However, cracks or other damage on the outside wall, the aluminum-composite interface, or the sealing surface should be inspected by your Beckman Coulter representative.

Repeated autoclaving of the cannisters may cause the following conditions, all of which are cosmetic in nature during the 7-year warranty period:

- an increase in the number of surface cracks in the dome area,
- increased visibility of existing surface cracks,
- a change in cannister color due to oxidation of the epoxy, and
- formation of a white, powdery residue on the outside wall of the cannister; this residue can be wiped off with a soft, damp cloth.

---

<sup>4</sup> Ultem is a registered trademark of GE Plastics.

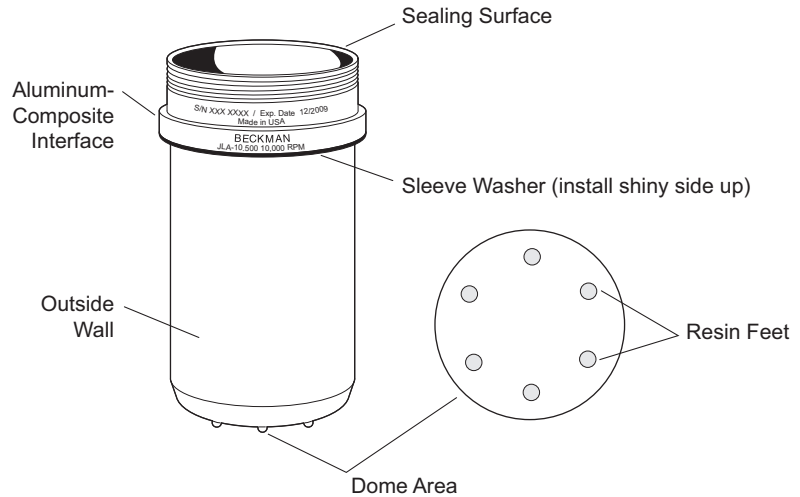

Figure 4. Cannister Dome Area

## ROTOR BODY INSPECTION AND MAINTENANCE

### NOTE

Do not use sharp tools on the rotor that could cause scratches in the rotor surface. Corrosion begins in scratches and may open fissures in the metal with continued use. Do not use sharp objects or tools on the composite cannisters, as the composite material is easily damaged.

- Periodically (at least monthly) inspect the rotor body, especially inside cavities, for rough spots or pitting, or heavy discoloration. If any of these signs are evident, do not use the rotor. Contact your Beckman Coulter representative for information about the Field Rotor Inspection Program and the rotor repair center.
- To prevent corrosion of the aluminum rotor body, store the rotor in a dry environment with the lid removed. Do not store the rotor in the centrifuge.
- To prevent abrasion of the metal rotor tie-down components, place the rotor lid upside down on a flat surface and put two or three drops of Tri-Flow<sup>5</sup> oil between the lid adapter and the lid stem (see Figure 5). This area should be lubricated every few weeks or after each autoclave cycle.

<sup>5</sup> Tri-Flow is a registered trademark of Thompson & Formby, Inc.

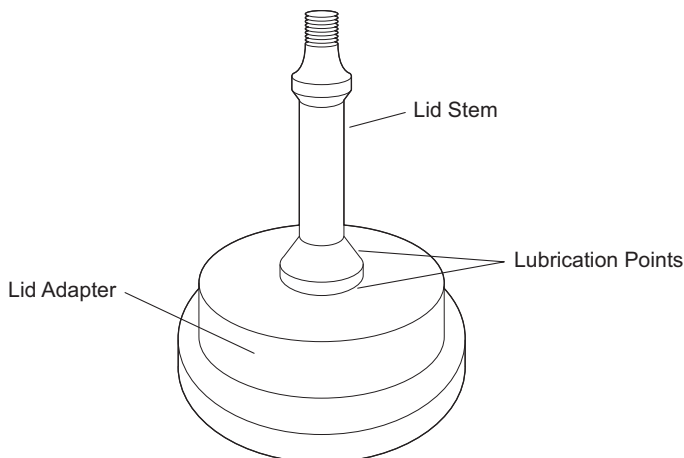

Figure 5. Lubricating the Lid Stem

Refer to Appendix A in *Rotors and Tubes* for chemical compatibilities of rotor and accessory materials. Your Beckman Coulter representative provides contact with the Field Rotor Inspection Program and the rotor repair center.

## CLEANING

---

*Wash the rotor and rotor components immediately if salts or other corrosive materials are used or if spillage has occurred. Do not allow corrosive materials to dry on the rotor.*



Under normal use, wash the rotor frequently (at least weekly) to prevent buildup of residues.

1. Wash the rotor, rotor lid, and cannisters in a mild detergent, such as Beckman Solution 555, that won't damage the rotor. The Rotor Cleaning Kit (339558) contains two special plastic-coated brushes and two quarts of Solution 555 for use with rotors and accessories. Dilute the detergent 10 to 1 with water.

### NOTE

Do not wash the rotor components or accessories in a dishwasher. Do not soak components in detergent solution for long periods of time, such as overnight.



2. Thoroughly rinse the cleaned rotor and components with distilled water.
3. Air-dry the rotor, lid, and cannisters upside down. *Do not use solvents such as acetone to dry rotor components.*



#### CAUTION

*Do not use acetone, MEK (methyl ethyl ketone), chloroform, cyclohexane, or organic solvents on the cannisters at any time. These substances will damage the epoxy resin surface material.*

## DECONTAMINATION



If the rotor body becomes contaminated with radioactive material, it should be decontaminated using a solution that will not damage the anodized surfaces. Beckman Coulter has tested a number of solutions and found several that do not harm anodized aluminum: RadCon Surface Spray or IsoClean Solution (for soaking),<sup>6</sup> and Radiacwash.<sup>7</sup>

#### NOTE

IsoClean can cause fading of colored anodized surfaces. Use it only when necessary and remove it promptly from rotor surfaces.

For radioactive decontamination of the cannisters, RadCon Surface Spray and Radiacwash can be used. Do not soak the cannisters in these solutions; *use the minimum immersion times specified by the solution manufacturers.*

While Beckman Coulter has tested these methods and found that they do not damage components, no guarantee of decontamination is expressed or implied. Consult your laboratory safety officer regarding the proper decontamination methods to use.

<sup>6</sup> In U.S.A., contact Nuclear Associates (New York); in Eastern Europe and Commonwealth States, contact Victoreen GmbH (Munich); in South Pacific, contact Gammasonics Pty. Ltd. (Australia); in Japan, contact Toyo Medic Co. Ltd. (Tokyo).

<sup>7</sup> In U.S.A., contact Biodex Medical Systems (Shirley, NY); internationally, contact the U.S. office to find the dealer nearest you.



If the rotor or other components are contaminated with toxic or pathogenic materials, follow appropriate decontamination procedures as outlined by your laboratory safety officer. Refer to Appendix A in *Rotors and Tubes* to evaluate your rotor's ability to withstand a given chemical solution.



### CAUTION

*Strongly alkaline solutions will damage the rotor body.*

## STERILIZATION AND DISINFECTION

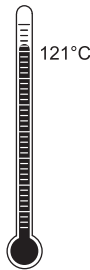

- The rotor body, cannisters, and tube adapters can be autoclaved at 121°C for 30 minutes. Remove cannisters from the rotor body and remove cannister closures during autoclaving.
- Ethanol (70%)<sup>8</sup> and hydrogen peroxide (6%) may be used on all rotor components. Bleach (sodium hypochlorite) may be used, but may cause discoloration of anodized surfaces. *Use the minimum immersion time for each solution, per laboratory standards.*

While Beckman Coulter has tested these methods and found that they do not damage the rotor or components, no guarantee of sterility or disinfection is expressed or implied. When sterilization or disinfection is a concern, consult your laboratory safety officer regarding proper methods to use.

Refer to publication IN-192, included in each box of tubes and bottles, for tube and bottle sterilization and disinfection procedures.

## TUBE BREAKAGE

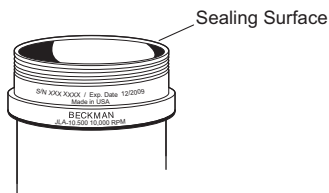

If a glass tube or bottle breaks, remove the glass carefully from the cannister and/or adapter. Embedded glass particles that remain in the cannister or adapters can damage the cannister and cause tube failure during subsequent runs. Clean cannisters thoroughly *immediately* following a tube breakage. Be especially careful not to scratch the sealing surface. This surface must be smooth and undamaged in order to ensure a tight seal with the closure O-ring.

<sup>8</sup> Flammability hazard. Do not use in or near operating centrifuges.

## RETURNING A ROTOR

Before returning a rotor, cannister, or accessory for any reason, prior permission (a Returned Goods Authorization form) must be obtained from Beckman Coulter, Inc. This RGA form, which may be obtained from your local Beckman Coulter sales office, should contain the following information:

- serial number of rotor and cannister(s),
- expiration date of cannister(s),
- history of use (approximate frequency of use and autoclave cycle history),
- reason for the return,
- original purchase order number, billing number, and shipping number, if possible,
- name and phone number of the person to be notified upon receipt of the rotor or accessory at the factory, and
- name and phone number of the person to be notified about repair costs, etc.

To protect our personnel, it is the customer's responsibility to ensure that the parts are free from pathogens and/or radioactivity. Sterilization and decontamination must be done before returning the parts. Smaller items (such as tubes, bottles, etc.) should be enclosed in a sealed plastic bag.

*All parts must be accompanied by a note, plainly visible on the outside of the box or bag, stating that they are safe to handle and that they are not contaminated with pathogens or radioactivity. **Failure to attach this notification will result in return or disposal of the items without review of the reported problem.***

Use the address label printed on the RGA form when mailing the rotor and/or accessories.

Customers located outside the United States should contact their local Beckman Coulter office.

## SUPPLY LIST

### NOTE

Publications referenced in this manual can be obtained by calling Beckman Coulter at 1-800-742-2345 in the United States, or by contacting your local Beckman Coulter office.

Contact Beckman Coulter Sales (1-800-742-2345 in the United States) or your local Beckman Coulter office, or see the *High Performance, High Speed, High Capacity Rotors, Tubes & Accessories* catalog (BR-8102, available at [www.beckmancoulter.com](http://www.beckmancoulter.com)) for detailed information on ordering parts and supplies. For your convenience, a partial list is given below.

## REPLACEMENT ROTOR PARTS

JLA-10.500 rotor assembly with magnets (rotors manufactured Jan. 2002 and later) . . . . .	369681
JLA-10.500 rotor assembly (rotors manufactured through Dec. 2001) . . . . .	360830
Cannisters (set of 2 with 2 cannister closures) . . . . .	360828
Cannister closure assembly (1) . . . . .	360842
Cannister closure O-ring (set of 12) . . . . .	360848
Cannister sleeve washer . . . . .	360834
Rotor lid assembly . . . . .	363334

## SUPPLIES

Bottles, tubes, and adapters . . . . .	see Tables 3 and 4
Bottle caps for 500-mL bottles 361690 and 361691 (set of 6, Noryl <sup>9</sup> ) . . . . .	360954
Cannister rack . . . . .	363335
Rotor Cleaning Kit . . . . .	339558
Silicone vacuum grease (1 oz) . . . . .	335148
Solution 555 (1 qt) . . . . .	339555
Spinkote lubricant (2 oz) . . . . .	306812
Tri-Flow lubricant (2 oz) . . . . .	883371

<sup>9</sup> Noryl is a registered trademark of GE Plastics.

---

## JLA-10.500 ROTOR WARRANTY

Subject to the conditions specified below and the warranty clause of the Beckman Coulter, Inc., terms and conditions of sale in effect at the time of sale, Beckman Coulter agrees to correct either by repair, or, at its election, by replacement, any defects of material or workmanship which develop within seven (7) years after delivery of the JLA-10.500 rotor to the original buyer by Beckman Coulter or by an authorized representative, provided that investigation and factory inspection by Beckman Coulter discloses that such defect developed under normal and proper use. Should a Beckman Coulter centrifuge be damaged due to a failure of a rotor covered by this warranty, Beckman Coulter will supply free of charge all centrifuge parts required for repair.

### REPLACEMENT

Any product claimed to be defective must, if requested by Beckman Coulter, be returned to the factory, transportation charges prepaid, and will be returned to Buyer with the transportation charges collect unless the product is found to be defective, in which case Beckman Coulter will pay all transportation charges.

A defective rotor will be replaced by Beckman Coulter at its then current list price less a credit based upon the age of the rotor (years since date of purchase). The Buyer shall not receive credit until the claimed defective rotor is returned to Beckman Coulter's Indianapolis, Indiana facility or delivered to a Beckman Coulter Field Service representative.

The replacement price (cost to Buyer) for the respective rotor shall be calculated as follows:

$$\text{Replacement price} = \text{Current rotor list price} \times \frac{\text{years}}{7}$$

### CONDITIONS

1. Except as otherwise specifically provided herein, this warranty covers the JLA-10.500 rotor only and Beckman Coulter shall not be liable for damage to accessories or ancillary supplies including but not limited to (i) tubes, (ii) tube caps, (iii) tube adapters, or (iv) tube contents.

2. This warranty is void if the rotor has been subjected to customer misuse such as operation or maintenance contrary to the instructions in the Beckman Coulter rotor or centrifuge manual.
3. This warranty is void if the JLA-10.500 rotor is operated with a rotor drive unit or in a centrifuge unmatched to the rotor characteristics, or is operated in a Beckman Coulter centrifuge that has been improperly disassembled, repaired, or modified.
4. Each JLA-10.500 cannister, whether purchased with a rotor assembly or purchased separately, is covered by this warranty for seven (7) years from the date of purchase, and will be replaced or repaired during such period according to the terms and conditions of this warranty. The date of manufacture marked on the cannister may be earlier than the date of purchase, and the expiration date marked on the cannister, which is seven (7) years after the date of purchase, may be correspondingly offset.
5. JLA-10.500 cannisters should not be used after the expiration date marked on the cannister. If at the time of purchase the marked expiration date is less than 7 years from the date of purchase, the expiration date becomes the date of purchase plus seven (7) years. Use of a cannister after such expiration date voids Beckman Coulter's warranty obligations with respect to any rotor and/or centrifuge in which such a cannister is used.

### DISCLAIMER

IT IS EXPRESSLY AGREED THAT THE ABOVE WARRANTY SHALL BE IN LIEU OF ALL WARRANTIES OF FITNESS AND OF THE WARRANTY OF MERCHANTABILITY AND THAT BECKMAN COULTER, INC., SHALL HAVE NO LIABILITY FOR SPECIAL OR CONSEQUENTIAL DAMAGES OF ANY KIND WHATSOEVER ARISING OUT OF THE MANUFACTURE, USE, SALE, HANDLING, REPAIR, MAINTENANCE, OR REPLACEMENT OF THE PRODUCT.





Beckman Coulter, Inc. • 250 S. Kraemer Blvd. • Brea, California 92821 U.S.A.  
Sales and Service: 1-800-742-2345 • Internet: [www.beckmancoulter.com](http://www.beckmancoulter.com) • Printed in U.S.A.

© 2014 Beckman Coulter, Inc.  
All rights reserved